

FECHO CONCHA 2010

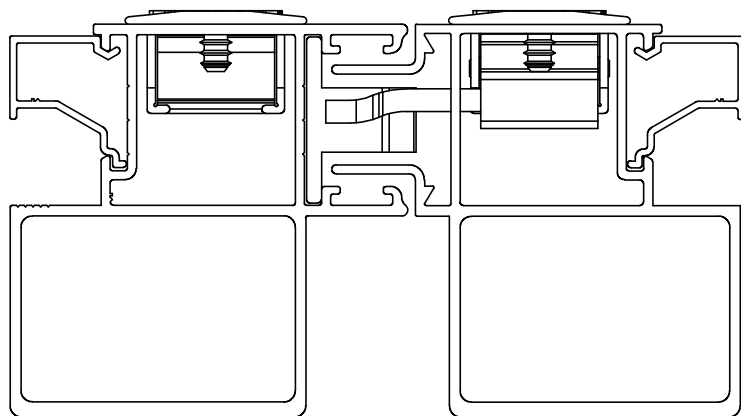

Aplicação



escala 1:1

Características

COMPONENTES	MATÉRIA-PRIMA
Mecanismo	Alumínio
Estrutura	Alumínio
Componentes	Polímero

Componentes de fixação	Dimensões	Qtde.
Parafuso	A4,2x8 CHA/PH INOX	2

Embalagem	1 Concha
	2 Parafusos

CODIFICAÇÃO

Cor	Código	Catálogo
BCO	9208918	CON2010BCO
BP3	9208919	CON2010BP3
PRA	9208920	CON2010PRA
PTF	9208921	CON2010PTF

Dimensional Fecho

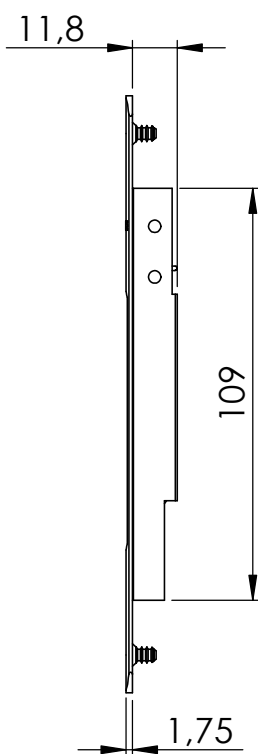

Usinagem ①

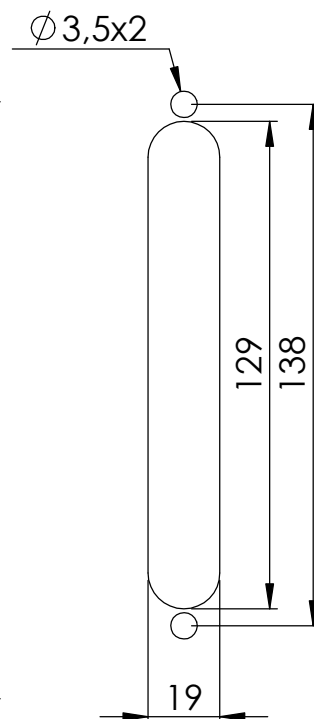

escala 1:2

Ref. Usinagem

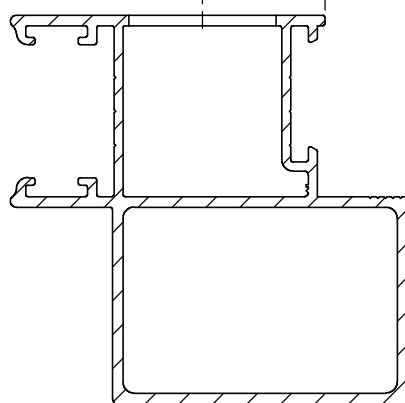
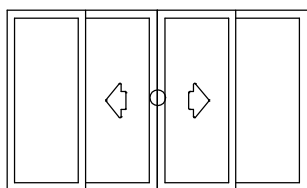
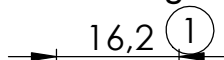

escala 1:1

JANELA DE CORRER
LINHA SUPREMA

UDINESE